



S E R I E S

5 9 6



INDUSTRY LEADING  
COMMERCIAL & INDUSTRIAL SOLUTIONS

# Extra Heavy-Duty Thermacore® Insulated Steel Door System With Sound Suppression Capabilities

**SERIES 596**



## Standard Features At a Glance

Panel thickness	2" (51 mm)
R-value	17.40 (3.06 W/Msq)
U-value	.057 (.327 Msq/W)
Air infiltration:	
at 15 mph (24 kmph)	.08 cfm (2.26 Lpm)
at 25 mph (40 kmph)	.08 cfm (2.26 Lpm)
Thermal break	PVC
Exterior steel	20-gauge galvanized
Exterior surface	flush, textured
Standard springs	10,000 cycle
Sound transmission rating	Class 26
Std. maximum width	36'2" (11,024 mm)
Std. maximum height	24'1" (7,341 mm)
Exterior color	White, Industrial Brown, Gray or Tan
Interior color	White
Limited Warranty	10-year delamination

## Options

- Windload
- Thermal glazing
- Four-section pass door
- Knock & Lock® Breakaway door system
- High-usage package
- Jamb weatherstrip
- Electric operator or chain hoist
- Posi-Tension drums
- Stop bottom fixture
- Bottom sensing edge
- Rubber header seal
- Aluminum sash section available to 24'2" (7366 mm) wide
- Mounted slidelock or keyed lock
- Exhaust ports

## Exceptional Thermal Efficiency

The Thermacore® 596 Series features an R-value of 17.40 (3.06 W/Msq), a U-value of .057 (.327 Msq/W), and one of the best overall air infiltration ratings in the industry – as well as a Class 26 sound transmission rating. Ideal for extra heavy-duty applications where both thermal efficiency and sound suppression are desirable, this 2" (51 mm) thick door is available in standard sizes up to 36'2" (11,024 mm) wide and 24'1" high (7,341 mm).

The 596 Series incorporates the Thermacore® steel-polyurethane-steel panel construction, which provides a thermal barrier to withstand harsh climates and demanding environmental requirements. The result is a solid, well-built door that keeps both the weather and unwanted sound at bay.

### Built With the Best Technology in the Business.

The 596 Series is manufactured using Overhead Door Corporation's proprietary, computer-controlled fabrication process. This advanced technology ensures adherence to the industry's strictest product tolerances and results in an exceptionally well-built door for outstanding thermal efficiency and long-lasting performance.

### Highly Engineered for High Thermal Efficiency.

The Thermacore® product line's unique manufacturing process provides a CFC-free, fully encapsulated, foamed-in place panel which maintains R-value performance year round – and year in and year out. Thermal breaks between internal and external skins, PVC thermal break and joint seal minimize air infiltration and provides one of the highest thermal efficiency ratings in the industry for specified applications.

### Strong, Lightweight, Attractive and Durable.

Thermacore® 596 doors feature 20-gauge, roll-formed, hot-dipped galvanized steel exterior panels for exceptional strength and sound suppression capabilities. Windload design available as an option. Two coats of white baked-on, polyester paint on a flush, textured exterior surface







## and Superior Sound Suppression

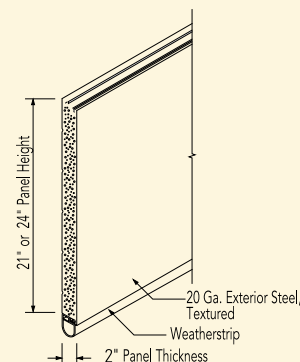

Overhead Door Corporation's line of Thermacore® steel-polyurethane-steel sandwich panel construction is lightweight, incredibly strong and exceptionally efficient – reflecting a premium level of thermal performance.

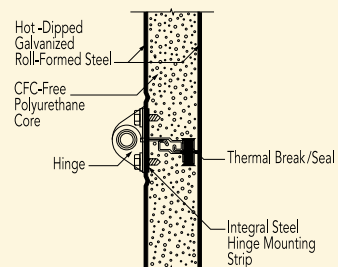

Installation and Service: Overhead Door Company of Twin Falls

provide a handsome finish that will last for years. Our industry-leading 10-year limited warranty against delamination means that we'll stand behind the quality of our doors at the outset and for the long haul.

### Superior Field Serviceability.

Thermacore® has a special internal construction which allows hinges to be placed anywhere along the panel's length permitting customization on the job site — for fast and precise installation, repair or retrofit.

### Many Options, Better Solutions.

The Thermacore® 596 is available in sizes up to 36'2" (11,024

mm) wide and 24'1" (7,341 mm) high. A full line of electric operators ensures precise and trouble-free motor operation in a variety of mounting options (side, center or trolley). Available options include aluminum sash section, thermal glazing, pedestrian pass door, Knock & Lock® Breakaway door system, and jamb weatherstripping. An optional high-usage package expands the versatility of the 596 to high-cycle conditions, with torsion springs in 25k, 50k, 75k or 100k cycles, a solid-steel shaft to reduce fatigue and deflection, and a heavy-duty 3" (76 mm) steel track for added durability.

---

## The Original, Innovative Choice for Unequaled Quality and Service

---

**Overhead Door Corporation pioneered the upward-acting door industry, inventing the first upward-acting door in 1921 and the first electric door operator in 1926. Today, we continue to be the industry leader through the strength of our product innovation, superior craftsmanship and outstanding customer support, underscoring a legacy of quality, expertise and integrity. That's why design and construction professionals specify Overhead Door Corporation products more often than any other brand.**

The red Overhead Door Ribbon is a mark of quality that also reflects the pride we take in the people who support our products. Our family of over 450 Ribbon Distributors across the country not only share our name and logo, but also our commitment to excellence. Your Ribbon Distributor will work with you in a consultative role to ensure that product selections achieve your design and application requirements — in addition to offering expert installation, professional field service and ongoing maintenance. From project design and manufacturing to installation and service, the Overhead Door Ribbon is your guarantee of genuine quality and turnkey service excellence.

**Together with our Ribbon Distributors, we offer comprehensive technical information and resource materials to support your project, including:**

- Architectural Design Manual – a comprehensive guide to selecting, specifying and detailing all commercial and industrial Overhead Door products
- Sweet's Catalog for selection information about our products, and Sweet's CD and CD-CAD for convenient electronic product information, technical specifications, and details with CAD "cut-and-paste" capability
- Operation & Maintenance Manual – detailed product information, customized for your project, to ensure reliable, long-life door system operation
- Custom design and technical assistance through our Corporate Application Engineering Teams
- Visit our Architect's Corner at [www.OverheadDoor.com](http://www.OverheadDoor.com)



Advanced Rolling Steel Door  
RapidSlat®



Thermacore® Sectional Doors



Rolling & Side Folding  
Security Grilles & Closures



Rolling Service Doors



Commercial Operators

Today, Overhead Door Corporation—along with our Horton Automatics division, for automated pedestrian entrances—is recognized as the leading, single-source manufacturer of integrated door and operator systems for commercial, industrial and residential applications. With multiple manufacturing locations throughout the United States, a state-of-the-art TREQ (Testing, Reliability, Engineering, and Quality) Center for design and engineering, and a national network of authorized Ribbon Distributors, our capabilities are leading-edge and our field service and technical support second to none. Built best and backed best, Overhead Door is the industry's leading choice for quality that shows and lasts.

**To talk with the Overhead Door distributor nearest you, call 1-800-929-DOOR.**

### Overhead Door Corporation

2501 S. State Hwy. 121 Bus., Suite 200

Lewisville, Texas 75067

1-800-929-DOOR

[www.OverheadDoor.com](http://www.OverheadDoor.com)



**INDUSTRY LEADING  
COMMERCIAL & INDUSTRIAL SOLUTIONS**

The Overhead Door Corporation family of quality commercial and industrial products includes:



A part of Sanwa Shutter Corporation